

Hyster offer our clients a wide range of wear products and professional wear solutions. We also welcome custom made one off's and consumables.

Some of our products and services:

- Bimetallic wear plates
- Chocky bars and wear buttons
- White iron wear blocks, wear bars
- Bimetallic wear pipes/Liners
- Bucket protectors
- Tungsten carbide wear parts
- Ni-Hard wear parts
- Sugar mill hammer tips
- Professional wear solutions
- Full Fabrication services
- Fast service and timely delivery



Laminated Wear Blocks are unique wear resistant materials in that they combine very high wear resistant qualities of a white iron (ASTM A532 15/3CrMo, 700BHN – 63HRC) with a weldable & high impact toughness mild steel through a metallurgical bond to create a product that is exceptionally resistant to impact and abrasion while retaining.

A. Chemical

C	Cr	Mn	Mo	Cu	P	Si	S	B, V, Nb
2.5-3.5	15-18	0.5-1.0	0.5-2.5	0.5-1.0	0.02max	0.5-1.0	0.02max	0.1-0.5

B. Mechanical Property:

- | | |
|-----------------------------|-------------|
| 1) <u>Tensile Strength</u> | 630Mpa Min. |
| 2) <u>Shearing Strength</u> | 250Mpa Min. |
| 3) <u>Hardness</u> | 63 HRC |

C. Micro-structure

Carbide + Martensite + Retained Austenite

The Carbide Content is about 41.4%

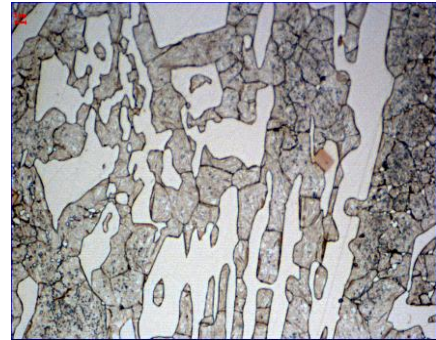
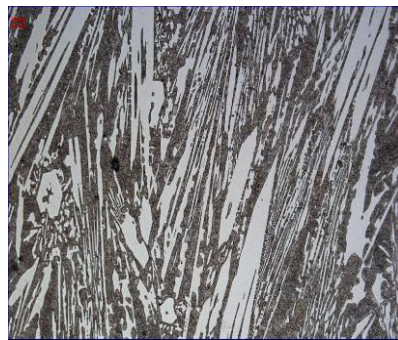
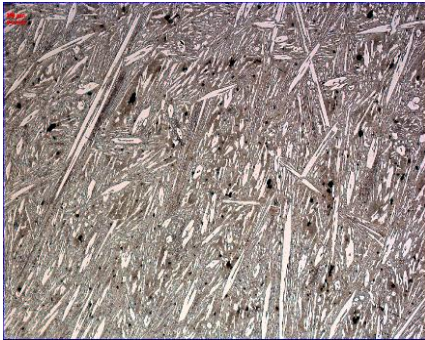

D. Application

Wear Pads
Jaw Crushers
Chute Linings
Ore Chutes
Crusher Chutes
Tripper Chutes
Flop Gates
Bucket Liners
Grizzly Bars

Lip Protectors
Screen Plates
Bucket Liners
Floor Liners
Loaders
Wear Aprons
Knife Inserts
Crusher Bars
Run Out Rolls

Dump Hoppers
Crusher Hoppers
Vibratory Feeders
Rock Box Edges
Surge Bin Liners
Rock Box Liners
Skip Liners
Trough Liners
Draglines

Concentration Bins
Buckets
Transition Pieces
Coal Transfer Chutes
Apron Feeder Liners
Loading Pocket Liners
Splitter/Divider Plates
Hammer Mill Inserts
Rolling Mill Guides

Hopper Edges
Shovels
Arm & Hub Liners
Bolt Protectors
Truck Bed Liners
Impact Wall Liners
Distribution Plates
Bucket Wheel Protection
Conveyor Transfer Points



Chocky Bars

The unique, formable design of Hyster-Wear chocky bars are available in various lengths, grades and sizes and can also be customized as per the clients specific need. Applications for Chocky Bars are wide and varied, ranging from specific wear protection on buckets for loaders, excavators and draglines machines, or for weld-on hammer tips for the re-cycling industry, or chute linings and rock box edges. They are easy to use and install. They can be bent, cut and formed to suit different surfaces.

The standard is 23mm thick, length is 240mm, width could be from 25mm from 150mm. We can also produce according to your special requests

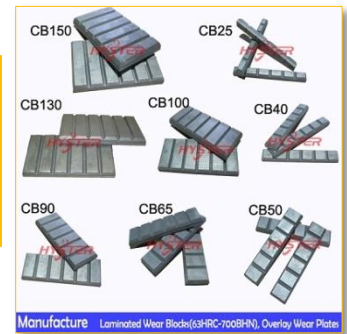

Item No.	Size (mm)	Dimension(mm)				N.W. (kg)
		A	B	C	D	
CB 25	240x25x23	240	25	15	23	0.9
CB 40	240x40x23	240	40	15	23	1.5
CB 50	240x50x23	240	50	15	23	1.9
CB 65	240x65x23	240	65	15	23	2.5
CB 80	240x80x23	240	80	15	23	3.2
CB 90	240x90x23	240	90	15	23	3.5
CB 100	240x100x23	240	100	15	23	3.9
CB 130	240x130x23	240	130	15	23	5.4
CB 150	240x150x23	240	150	15	23	6.0

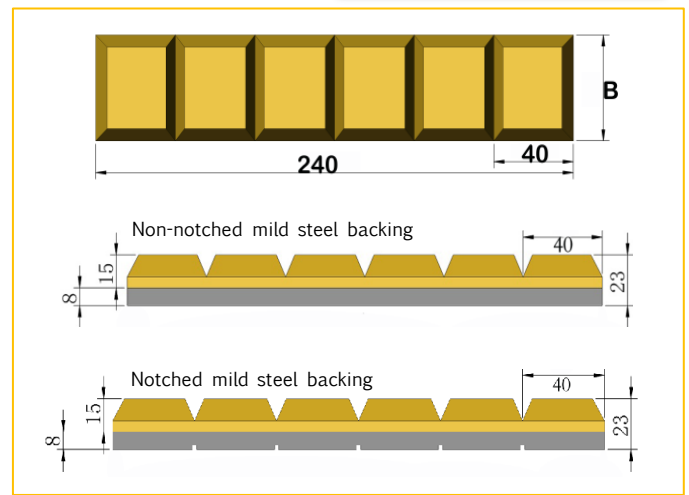

Wear Buttons

Item No.	Size (mm)	Dimension(mm)				N.W. (kg)
		A	B	C	D	
WB 60	∅60x27	60	27	17	10	0.7
WB 75	∅75x27	75	27	17	10	0.8
WB 90	∅90x27	90	27	17	10	1.4
WB 110	∅110x32	110	32	20	12	2.1
WB 115	∅115x32	115	32	20	12	2.5
WB 150	∅150x41	150	41	25	16	5.7

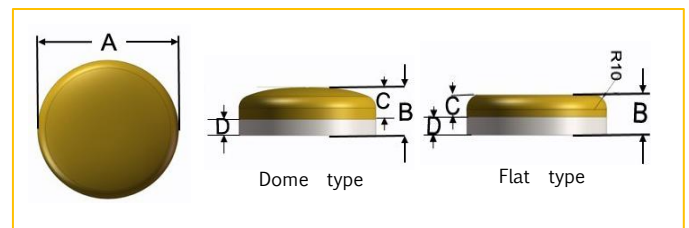

Wear Donuts

Item No.	Size (mm)	Dimension(mm)					N.W. (kg)
		A	B	C	D	E	
WD 75	∅75x25	75	25	17	8	25	0.7
WD 100A	∅100x25	100	25	17	8	50	1.0
WD 100B	∅100x32	100	32	24	8	70	1.0
WD 130	∅130x23	130	23	15	8	80	1.3
WD 148	∅148x35	148	35	25	10	108	2.2

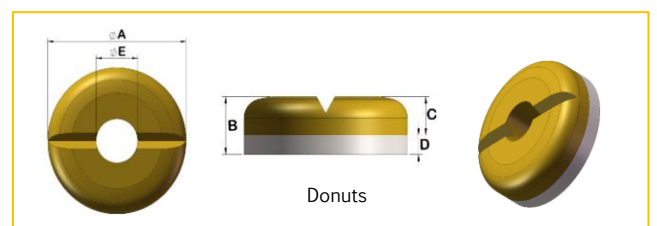

Standard Wear Bars

Item No.	Size (mm)	Dimension(mm)					N.W. (kg)
		A	B	C	D	E	
HSd 200A	200x25x25	200	25	15	10	25	1.0
HSd 200B	200x75x75	200	75	63	12	75	8.9
HSd 300A	300x25x25	300	25	15	10	25	1.5
HSd 153	153x38x33	153	38	25	8	33	1.5
HSd 300B	300x38x33	300	38	25	8	33	3.0
HSd 203	203x50x20	203	50	12	8	20	1.6
HSd 254	254x50x20	254	50	12	8	20	2.0
HSd 190A	190x50x30	190	50	20	10	30	2.2
HSd 65	65x50x50	65	50	38	12	50	1.3
HSd 115	115x50x50	115	50	38	12	50	2.3
HSd 127	127x50x50	127	50	38	12	50	2.4
HSd 150A	150x50x50	150	50	40	10	50	2.9
HSd 190B	190x50x50	190	50	40	10	50	3.7
HSd 210	210x50x50	210	50	38	12	50	4.1
HSd 230	230x50x50	230	50	38	12	50	4.5
HSd 294	294x50x50	294	50	40	10	50	5.8
HSd 300C	300x50x50	300	50	40	10	50	5.9
HSd 300D	300x150x60	300	150	48	12	60	21.1
HSd 432	432x50x50	432	50	38	12	50	8.5
HSd 459	459x38x31	459	38	25	6	31	4.2
HSd 600	600x50x50	600	50	38	12	50	11.8
HSd 250	250x60x20	250	60	12	8	20	2.4
HSd 150B	150x75x39	150	75	29	10	39	3.4
HSd 150C	150x75x50	150	75	40	10	50	4.4
HSd 150D	150x75x60	150	75	50	10	60	5.3
HSd 241	241x100x58	241	100	38	20	58	11.0



- Better wear resistance performance
- Durable
- Fine polish
- Cost effective
- Excellent quality

Note: Studs Extra

If arc studs are required, please stipulate the size and position required.

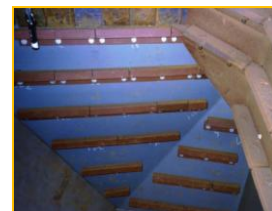
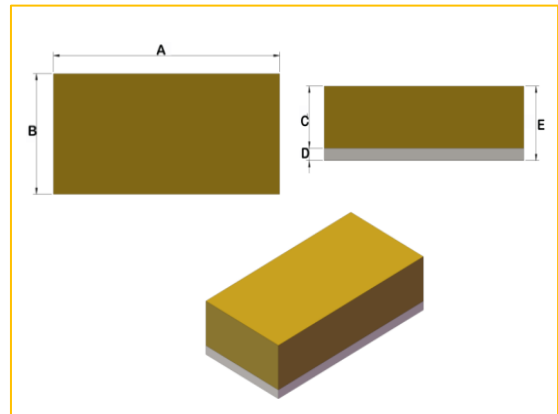

Microledges

Item No.	Size (mm)	Dimension(mm)				N.W. (kg)
		A	B	C	D	
HM 115	115x50	115	50	40	10	3.2
HM 127	127x50	127	50	38	12	3.6
HM 150	150x50	150	50	40	10	4.2
HM 190	190x50	190	50	38	12	5.5
HM 210	210x50	210	50	38	12	6.0
HM 230	230x50	230	50	38	12	6.6
HM 432	432x50	432	50	38	12	12.5

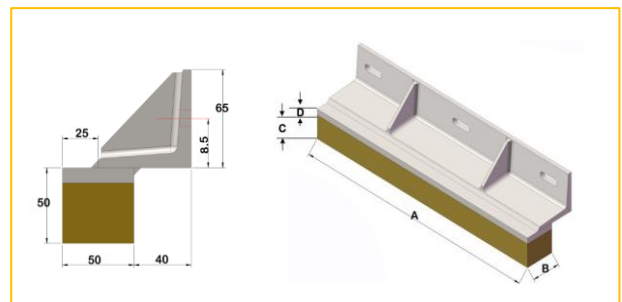

Wear Plates-Standard type/Trapezoidal type

Type	Item No.	Size (mm)	Dimension(mm)					N.W. (kg)
			A	B	C	D	E	
Standard	WP 200-18	200x200x18	200	200	12	6	18	5.7
	WP 200-20	200x200x20	200	200	14	6	20	6.3
	WP 300A	300x150x20	300	150	14	6	20	7.0
	WP 250	250x250x20	250	250	14	6	20	9.8
	WP 300C	300x300x18	300	300	12	6	18	12.7
	WP 300B	300x300x20	300	300	14	6	20	14.1
	WP 305	305x150x24	305	150	18	6	24	8.6
	WP 300C	300x150x25	300	150	19	6	25	8.8
	WP 300D	300x300x25	300	300	19	6	25	17.7
	WP 445	445x445x25	445	445	19	6	25	38.9
	WP 301	301x200x28	301	200	18	10	28	13.2
	WP 294A	294x144x30	294	144	20	10	30	10.2
	WP 294B	294x294x30	294	294	20	10	30	20.4
	WP 300E	300x150x30	300	150	20	10	30	10.6
	WP 300F	300x300x30	300	300	20	10	30	21.2
	WP 372	372x372x28	372	372	20	8	28	30.4
	WP 300G	300x300x50	300	300	40	10	50	35.3
	WP 300H	300x148x50	300	148	40	10	50	17.4
Trapezoidal	WPt 190	190x212.5x25	190	212.5	17	8	25	7.9
	WPt 241	241x290.5x30	241	290.5	22	8	30	19.5

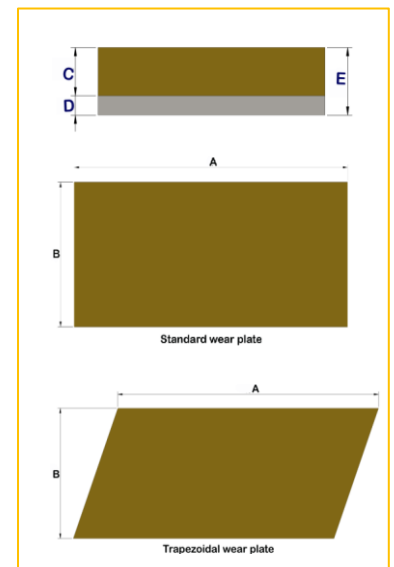

Note: Studs Extra
If arc studs are required, please stipulate the size and position required.

Notched Wear Plates - 3mm deep notch

Type	Item No.	Size (mm)	Dimension(mm)					N.W. (kg)
			A	B	C	D	E	
Star	WPs 400	400x400x23	400	400	15	8	23	28.7
Cross	WPC 200	200x200x12	200	200	6	6	12	3.8
	WPC 300	300x300x12	300	300	6	6	12	8.5

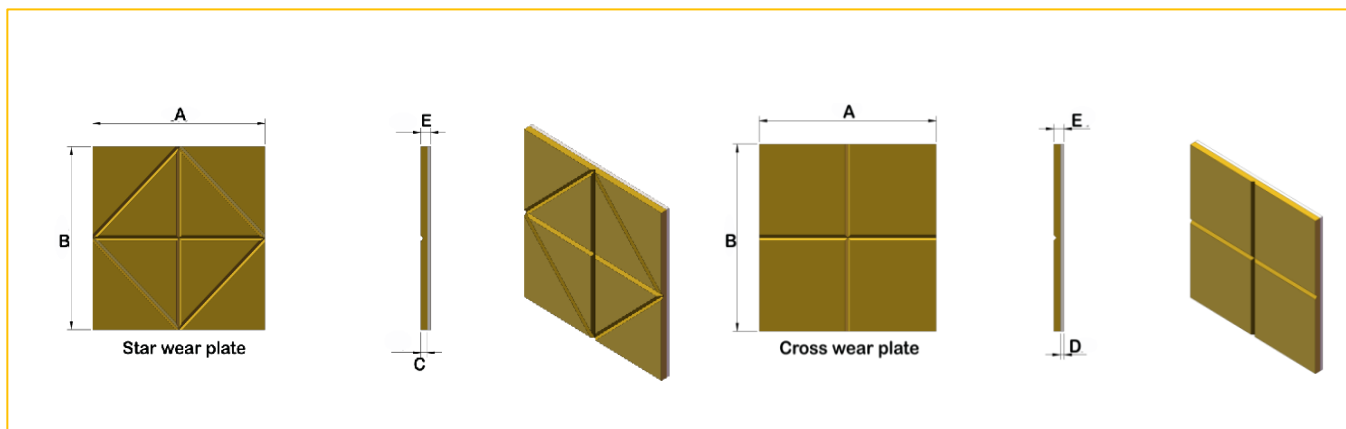
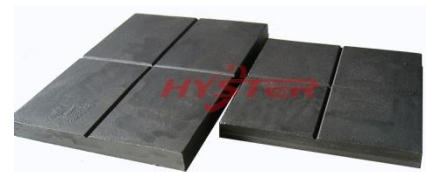

Rockbox Liners

Item No.	Size (mm)	Dimension(mm)							N.W. (kg)
		A	B	C	D	E	F	G	
RL 300A	300x300x50	300	300	30	10	10	50	50	28.7
RL 300B	300x148x50	300	148	30	10	10	50	50	13.8
RL 148A	148x452x50	148	452	30	10	10	50	50	21.1
RL 148B	148x300x50	148	300	30	10	10	50	50	14.0

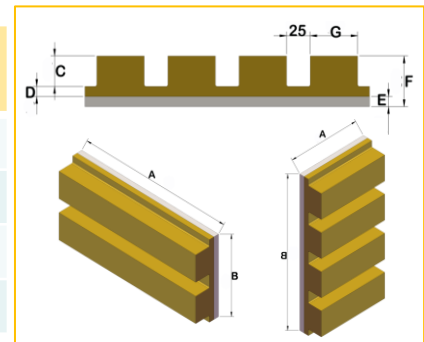

Skid Wear Bars

Type	Item No.	Size (mm)	Dimension(mm)					N.W. (kg)
			A	B	C	D	E	
1	SB1-214	214x101x34	214	101	22	12	34	5.1
	SB1-302	302x101x34	302	101	22	12	34	7.3
	SB1-154	154x101x34	154	101	22	12	34	3.7
	SB1-279	279x75x34	297	75	22	12	34	6.1
2	SB2-214	214x101x34	214	101	22	12	34	5.9
	SB2-214R	214x101x34	214	101	22	12	34	5.9
	SB2-302	302x101x34	302	101	22	12	34	8.4
	SB2-302R	302x75x34	302	75	22	12	34	8.4
	SB2-154	154x101x34	154	101	22	12	34	4.2
	SB2-154R	154x75x34	154	75	22	12	34	4.2
3	SB3-250A	250x150x45	250	150	20	25	45	13.1
	SB3-200	200x150x45	200	150	20	25	45	10.5
	SB3-250B	250x250x45	250	250	20	25	45	21.9

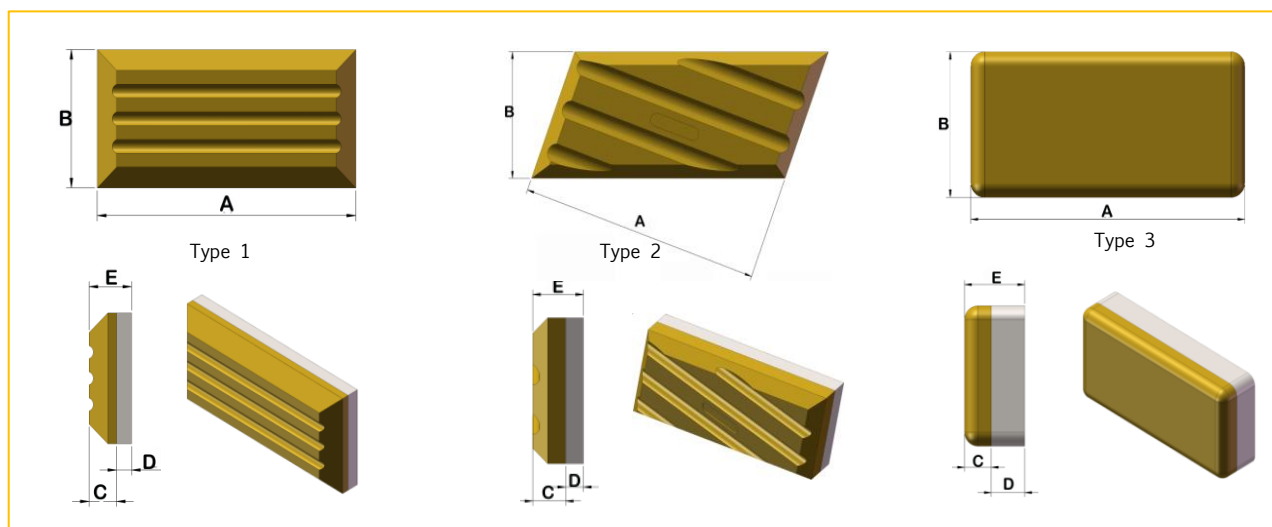
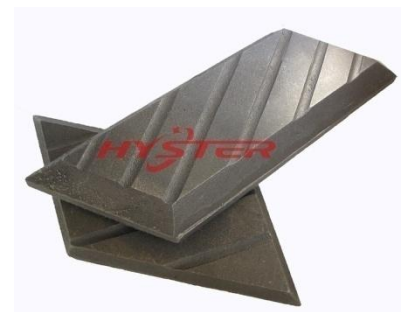

Shaped Wear Bars

Type	Item No.	Size (mm)	Dimension(mm)							N.W. (kg)
			A	B	C	D	E	F	G	
1	SWB 200	200x13x30	200	13	20	10	20	30	-	0.8
	SWB 244	244x10x35	244	10	25	10	25	35	-	1.3
	SWB 202	202x10x35	202	10	25	10	25	35	-	1.1
2	SWB 275	275x5x29	275	5	21	8	16	29	16	0.9
3	SWB 150	150x10x70	150	10	60	10	40	70	20	2.4
	SWB 200	200x25x59	200	3	47	12	25	59	-	1.5
	SWB 400	400x25x59	400	3	47	12	25	59	-	2.9
4	SWB 125	125x10x90	125	10	80	10	70	90	-	4.3
	SWB 200-4	200x25x50	200	10	38	12	25	50	-	1.5
	SWB 400-4	400x25x50	400	10	38	12	25	50	-	2.9

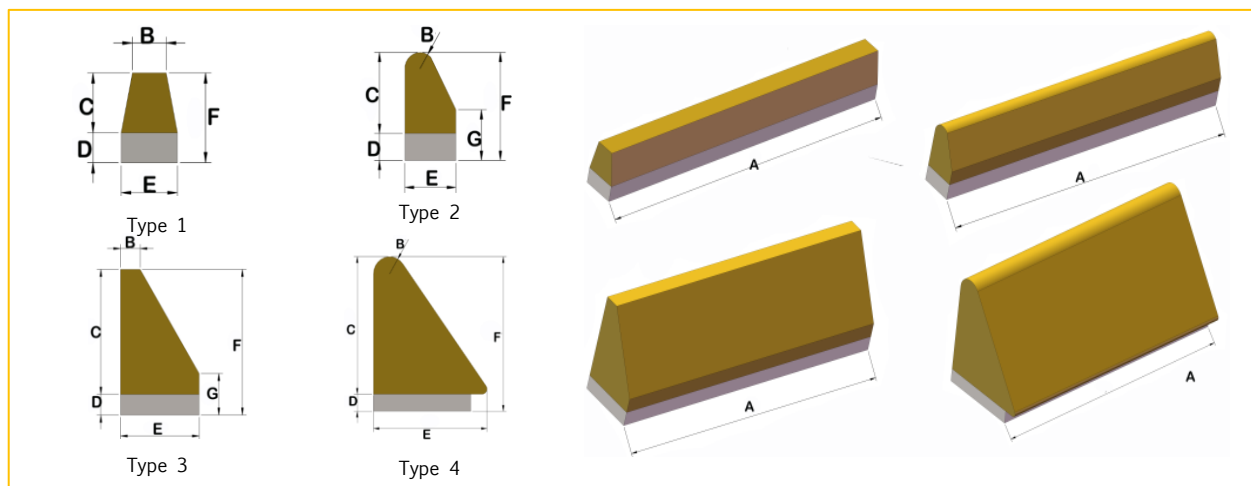
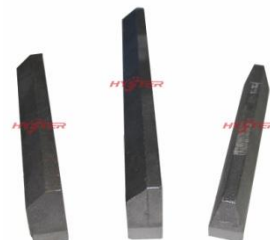

Wafer Strips

Item No.	Size (mm)	Dimension(mm)				N.W. (kg)
		A	B	C	D	
WS 25	240x25x12	240	25	6	6	0.6
WS 40	240x40x12	240	40	6	6	0.9
WS 50	240x50x12	240	50	6	6	1.2
WS 65	240x65x12	240	65	6	6	1.6

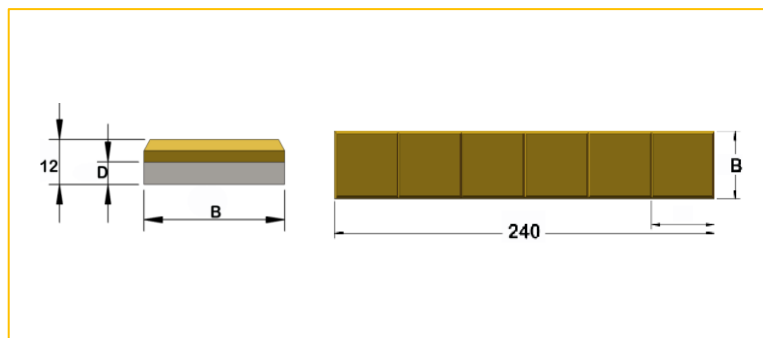
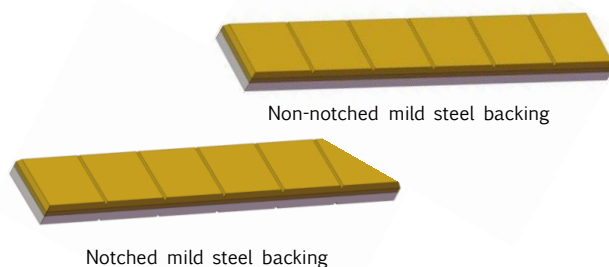

Grizzly Bars

Type	Item No.	Size (mm)	Dimension(mm)			N.W. (kg)
			A	B	C	
1	GB1-105	150x137.5	305	150	137.5	13.6
	GB1-137.5	137.5x125	305	137.5	125	12.5
	GB1-125	125x112.5	305	125	112.5	11.2
	GB1-112.5	112.5x100	305	112.5	100	10.0
	GB1-100	100x87.5	305	100	87.5	8.8
	GB1-87.5	87.5x75	305	87.5	75	7.5
	GB1-75	75x62.5	305	75	62.5	6.3
	GB1-62.5	62.5x50	305	62.5	50	5.1
2	GB2-150	150x141	305	150	141	13.8
	GB2-141	141x131	305	141	131	12.9
	GB2-131	131x122	305	131	122	11.9
	GB2-122	122x113	305	122	113	11.1
	GB2-113	113x103	305	113	103	10.1
	GB2-103	103x94	305	103	94	9.2
	GB2-94	94x84	305	94	84	8.3
	GB2-84	84x75	305	84	75	7.4

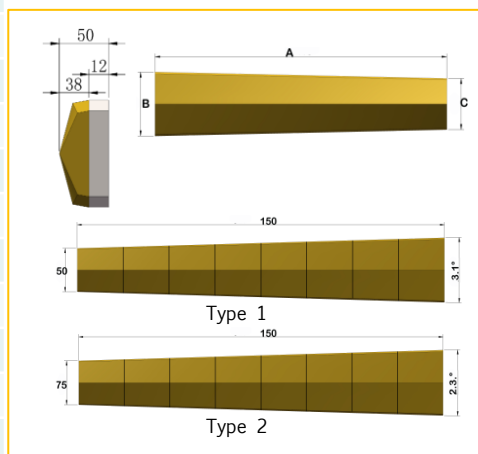

Elbow Wear Bars

Item No.	Size (mm)	Dimension(mm)					N.W. (kg)
		A	B	C	D	E	
HE 120	120x120x28	120	30	18	10	28	1.3
HE 180	180x180x32	180	40	22	10	32	3.0

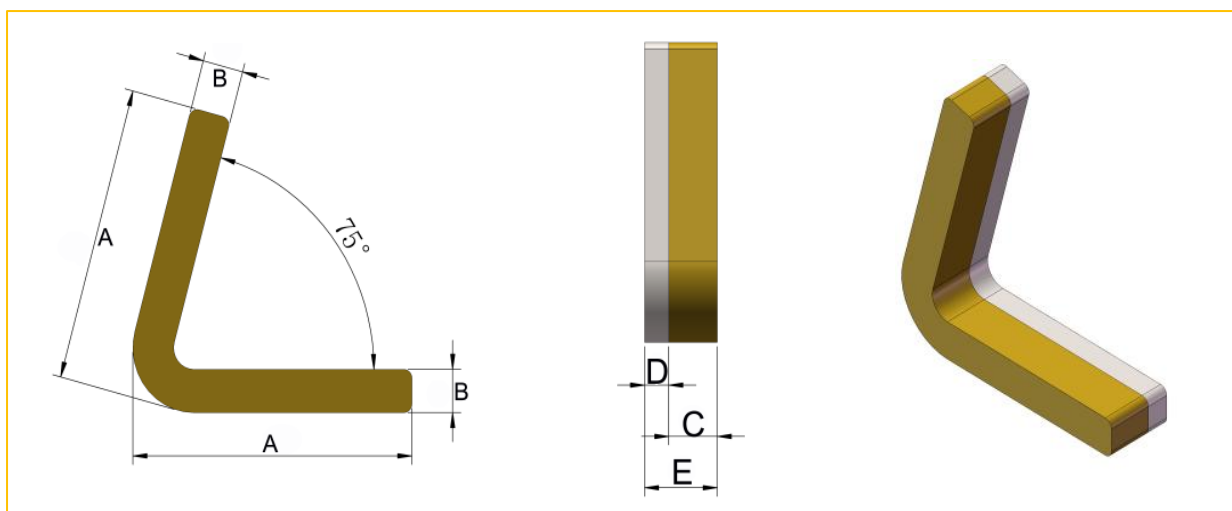

Shredder Hammer Tips

These are bi-metallic composites having 700BHN hardness and available in various sizes and shapes, shredder hammer tips can be used in sugar or coal industry to do crushing and shredding performance, it has excellent impact and abrasion resistance properties & enhanced service life.

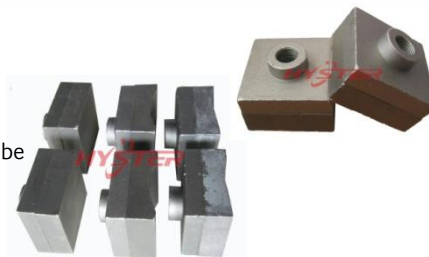

These hammers find application in

- i) Sugar Industry
- ii) Mining & Mineral Processing Industry.
- iii) Cement & Steel Industry

Note:

The standard size of F is 7/8"-14UNF, please inform us when other thread dimension is required.

Type	Item No.	Size (mm)	Dimension(mm)					N.W. (kg)
			A	B	C	D	E	
1	HC1 90-90	90x90x45	90	90	25	20	45	2.9
	HC1 90-50	90x50x45	90	50	25	20	45	1.6
	HC1 90-54	90x54x66	90	54	48	18	66	2.5
	HC1 50-50	50x50x38	50	50	20	18	38	0.7
	HC1 80-80	80x80x45	80	80	25	20	45	2.4
	HC1 100-100	100x100x45	100	100	25	20	45	3.6
	HC1 64-64	64x64x40	64	64	20	20	40	1.2
	HC1 80-56	80x56x45	80	56	25	20	45	1.6
2	HC2 90-90	90x90x50	90	90	30	20	50	3.0
	HC2 80-56	80x56x50	80	56	30	20	50	1.8
3	HC3 90-90	90x90x50	90	90	30	20	50	3.0
	HC3 90-50	90x50x55	90	50	35	20	55	1.8
	HC3 90-56	90x56x55	90	56	35	20	55	1.9

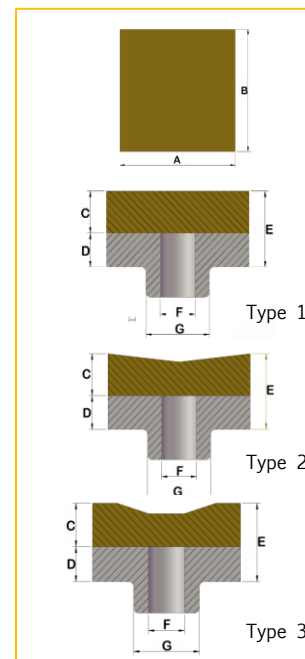

Knife Edges

Type	Item No.	Size (mm)	Dimension(mm)					N.W. (kg)
			A	B	C	D	E	
1	HK1 203-16	203x16x50	203	16	38	12	50	0.9
	HK1 203-19	203x19x50	203	19	38	12	50	1.1
	HK1 203-22	203x22x50	203	22	38	12	50	1.3
	HK1 203-25	203x25x50	203	25	38	12	50	1.5
	HK1 305-26	305x16x50	305	16	38	12	50	1.4
	HK1 305-19	305x19x50	305	19	38	12	50	1.6
	HK1 305-22	305x22x50	305	22	38	12	50	1.9
	HK1 305-25	305x25x50	305	25	38	12	50	2.2
2	HK2 203-16	203x16x50	203	16	38	12	50	1.0
	HK2 203-25	203x25x62	203	25	50	12	62	1.7
	HK2 305-25	305x25x56	305	25	40	16	56	2.5
3	HK3 203-19	203x19x50	203	19	38	12	50	1.6
	HK3 203-25	203x25x50	203	25	38	12	50	2.1
	HK3 203-28	203x28x50	203	28	38	12	50	2.3

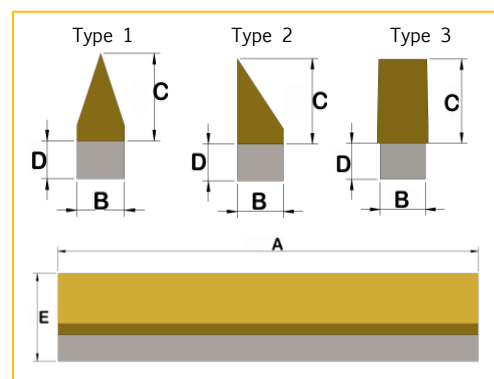

Chromium Carbide Overlay Wear Plates

OVERLAY-PLATE is welded by chromium carbide overlay on a mild steel backing plate. Manufactured by our own design's welding machine with exclusive technique.

OVERLAY-PLATE has excellent performance in abrasion resistant.

CHEMICAL COMPOSITION C 4.0%~5.5% Cr 21%~27%

BACKING PLATE Standard: SS400 mild steel or equivalent
Stainless or others upon request

HARDNESS HV600±

TOLERANCES ± 1mm

HEAT RESISTANCE Maximum: 400°C

MICROSTRUCTURE Mixture of high volume hexagonal shaped chromium carbide in tough austenitic and martensitic matrix(GRADE 2355)

PENETRATION TO THE BASE METAL 1.5mm

COLD FORMING Minimum Radius: 150mm(for 6+4) Suggested: using hydrolic press to bend plate

CUTTING Plasma(from backing plate side) / Laser Cutting / Water Jet Knife

APPLICATIONS

- Ash liners
- Bucket & Lips
- Classifier
- Ore chutes
- Extension ring
- Sinter breaker bar
- Blast furnace bell & burden
- Drag liners
- Fan blades & Housings
- Discharge funnels
- Cement kilns
- Conveyor casings
- Elbow
- Duct
- Mine car liners
- Slag chutes
- Grizzly bars
- Green Walt crushers
- Sinner plant
- Chute & Hopper liners
- Cyclones
- Dredge pump side plates
- Vibrator pan feeder liner
- Steel plant



Standard Overlays	Weight sq/m(kg)	Standard Sheet Size(mm)	Overall Thickness
4 ON 4	62	1500x3000 / 1200x2400	8
4 ON 6	77	1500x3000 / 1200x2400	10
6 ON 6	92	1500x3000 / 1200x2400	12
5 ON 8	100	1500x3000 / 1200x2400	13
6 ON 8	108	1500x3000 / 1200x2400	14
5 ON 10	116	1500x3000 / 1200x2400	15
9 ON 10	146	1500x3000 / 1200x2400	19
10 ON 10	157	1500x3000 / 1200x2400	20
12 ON 12	162	1500x3000 / 1200x2400	24
17 ON 12	222	1500x3000 / 1200x2400	29



Recommended Cutting Instruction for Hyster-Wear Blocks

High pressure water jet cutting is preferred cutting method for Hyster-wear blocks. Thermal cutting using an oxyacetylene torch, Arc-air or plasma is NOT recommended due to high localized heat penetration and high risk of cracking and delamination.

For Hyster Wear Blocks no greater than 25mm section thickness, cutting by abrasive disc is an accepted practice (Fig 1)

Caution: Extreme care must be taken when cutting to minimize local pre-heating or cracks and delamination may occur.

Alternatively, Hyster-Wear Blocks smaller than 25mm section thickness can be cut following the following procedure:

- Secure the piece to be cut in a vice or clamp
- Notch the backing plate as shown in Fig 2
- Notch the white iron a minimum of 3mm deep opposite the notch in the backing plate, as pre Fig 3
- Wrap the piece with a rag and carefully hit using a soft face hammer as shown in Fig4. The piece should break cleanly at the notch.

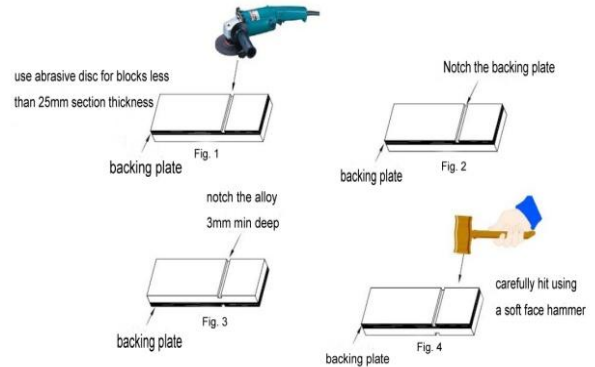

Recommended Forming Procedure for Hyster-Wear Blocks

This practice is suitable for chocky bars only

For severe curves with radius of less than 305mm, or inside curves, it is advisable to notch the mild steel backing plate opposite the "V" to assist forming.

It is normal the chocky block may crack during bending.

1. Clean the surface to which chocky block will be welded
2. Tack weld one end of the chocky block (as per the welding procedure) by 15mm minimum length per weld.
 - a. Outside curves:
Hammer down the unwelded end with a soft faced hammer to bend bar to match mating radius.
 - b. Inside curves:
Starting in the centre strike bar with a soft face hammer to bend bar to match mating radius.
3. Stitch weld as per the welding procedure.

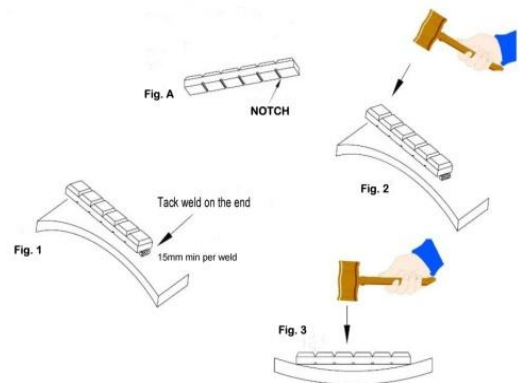

Recommended Welding Procedure for Hyster-Wear Blocks

Please Read All Procedures Completely

HYSTER recommends you always use a soft-face hammer and ANSI-approved (Z87.1) eye protection during cutting and bending procedures.

1. Ensure that the surface to which the Hyster-wear Blocks will be attached to is as flat as possible and the area to be welded is clean.
2. Clamp and tack weld Hyster-wear Blocks into position.
3. Stitch weld, laying 50mm max length on each run, alternating ends or sides to minimize heat penetration. Do NOT deposit weld within 2mm from the joint between alloy and steel backing plate
4. **DO NOT WELD CONTINUOUSLY**-Continuous welding may cause warpage, delaminating and cracking. Use thermal crayons to check temperature. Maximum allowed 200°C.
5. If a complete peripheral weld is required, use stitch weld method.
6. **WELDING RODS**- Hyster recommends low hydrogen weld rods or gas covered cored wire Gas shielded solid MIG wire – 1.2mm diameter max

Flux cored wire	-1.6mm diameter max to ASTM/AWS A5.18 classification ER705-6
Low hydrogen electrode	-3.25mm diameter max to ASTM/AWS A5.1 classification E7016-1H8 or E7018-1H4

WELDING PROCEDURE OVERVIEW

1. Read procedures completely
2. Tack weld into position
3. Stitch weld with max. length (50mm) each run
4. Maintain 2mm gap between weld and joint line

****CAUTION: TOO MUCH HEAT PENETRATION MAY CAUSE CRACKING AND SEPARATION.****

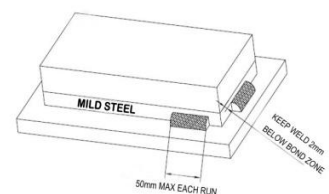

Factory Show

-Simple introduction

Hyster Material Technology Co.,LTD., is a casting expert with at least 17 years foundry experience in China. We own two foundry plants, one is in Changsha, Hunan province, with about 4000 sq. m. production area, and 36 working staffs, main duty is Researching, Testing, Machining, Welding, Packing. Another foundry plant is in Zhuzhou, also in Hunan province, with about 2500 sq. m. production area, and 28 working staffs, its main duty is making castings.

-Lab & Devices



HYSTER people welcome you visit our factory!



Distributed by: